

EPM-1B/1C

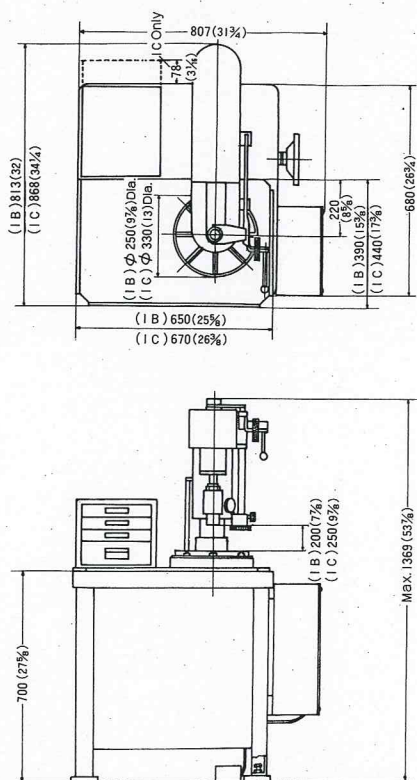

EPM-2A

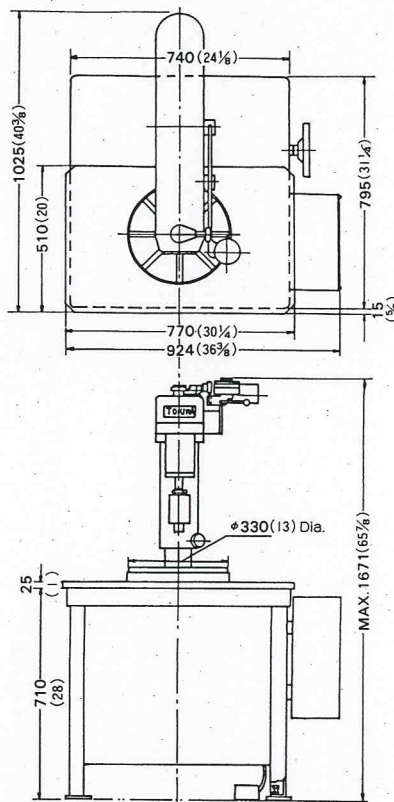

仕様 MACHINE SPECIFICATIONS

mm(inches)

	EPM-1B	EPM-3B	EPM-1C	EPM-3C	EPM-2A	EPM-3A
主軸回転数 Spindle speeds	2400rpm、2900rpm (50/60Hz)					
主軸電動機 Motor	0.2kW 200V 50/60Hz					
サドル上下電動機 Saddle UP/DOWN moter	0.2kw 200V 50/60Hz				0.4kw 200V 50/60Hz	
主軸の移動(首振り角度) Swivel range of spindle head	60°					
サドル上下の移動 Saddle vertical adjustment	150(5.91)		180(7)		300(11.81)	
主軸の上下スライド Spindle vertical travel	28(1.1)		60(2.36)	40(1.57)	100(3.94)	
砥石軸の振れの量(偏心量) Spindle eccentricity adjustment	0 ~ 1 (0-0.040)					
円テーブルの転り移動(360°任意の方向) Circular work table floating range(any direction in 360°)	制限なし Free					
円テーブルの転がり範囲(ヨコ×タテ) Circular work table repositioning range(left to right X front to back)	160×200 (6.3×8)		250×200 (9.8×8)		500×250 (20×9.8)	
ワーク最大寸法(概略mm)・重量kg Maximum work size Approx. mm(inches)・Weight Lb	550×400×150・<150> (22×16×6)・<330>		800×500×200・<200> (31.5×20×8)・<440>		900×600×320・<200> (35.4×24×12.6)・<440>	
機械本体最大寸法・重量kg Machine maximum measurement・Weight Lb	1,068×900×1,470・<390> (42×35.4×57.9)・<860>		1,068×952×1,500・<400> (42×37.5×59)・<880>		1,130×1,040×11,800・<460> (44.5×41×70.7)・<1,010>	

*仕様内容改良の場合若干の変更をすることがあります。

● The specifications indicated in this brochure are subject to change without prior notice.