

BMT Radial Drilling-Milling Head DW700-DF85-ER50-110

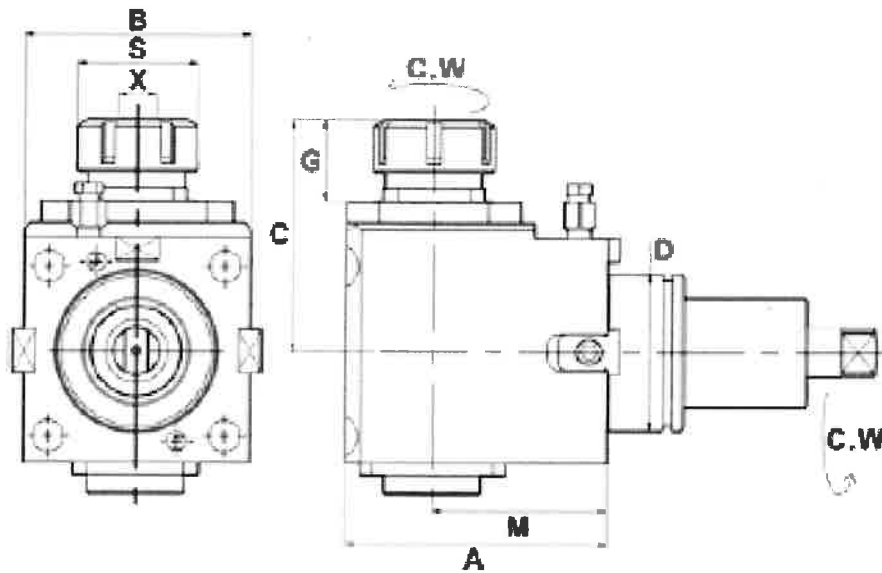

Figure L30000309: BMT Radial Drilling-Milling Head DW700-DF85-ER50-110

Table L30000309: BMT Radial Drilling-Milling Head DW700-DF85-ER50-110

Tool Holder Turret Interface:

Turret: RADIAL

Tooling Interface: BMT-85

Power Coupling: DIN1809

Y Axis: N/S

Part No.	D	X Capacity	S	Maximum R.P.M.	A	B	C	G	M	BMT size
DW220-DF45-ER20-65	45	1~13 ER20	35	5000	95	75	77.5	30	65	BMT45
DW220-DF45-ER25-65		1~16 ER25	42		95	75	81	32	65	
DW230-DF55-ER25-60	55	1~16 ER25	42	5000	86	85	81	31	60	BMT55
DW230-DF55-ER25-70					97	85	83	31.5	70	
DW230-DF55-ER25-80					106.5	85	82	31	80	
DW230-DF55-ER25-85					111.5	85	82	31	85	
DW300-DF65-ER32-65	65	2~20 ER32	50	5000	101	94	97.5	35.5	65	BMT65
DW300-DF65-ER32-72					108	94	96	34	72	
DW300-DF65-ER32-85					121	94	96.5	34.5	85	
DW300-DF65-ER32-100					137	94	96.5	34.5	100	
DW300-DF65-ER32-115					152	94	99.5	33.5	115	
DW350-DF75-ER40-60	75	3~26 ER40	63	5000	105	112	110.5	44	60	BMT75
DW350-DF75-ER40-70					115	112	106.5	39	70	
DW350-DF75-ER40-90					135	112	106.5	39	90	
DW350-DF75-ER40-125					170	112	110.5	44	125	
DW700-DF85-ER50-110	85	10~34 ER50	78	5000	136	125	141.5	50.5	110	BMT85

For the detailed list of compatible machine models - please click the **Compatible Machines** tab

- To be used for collet DIN 6499
- External Coolant supply
- Collet is not included